

Magnetostrictive Actuators



Nanoprecision

The position of the actuator can be controlled to a resolution of less than 50 nanometers with broad dynamic range.

High Force

The energy density of Energen actuators is the highest among smart material technology - three times that of piezoelectric material - providing for creative solutions when power and weight are at a premium.

Light Weight

Less weight is needed to generate the force and control you need because the power and motion of Energen actuators come directly from the magnetic smart materials.

Low Voltage

Energen actuators increase safety and reliability because they operate at less than 10 volts.

Low Vibration

Energen actuators introduce virtually no backlash or vibration because of their lack of moving parts.

Low Power

The power needs of Energen actuators are low, from less than one microwatt to tens of watts, depending on configuration.

Cryogenic Operation

Energen actuators operate at near absolute zero with the added benefit of delivering higher motion with the same force and precision as room temperature actuators.

Now, high force, nanoprecision motion can be yours with magnetostrictive actuators from Energen. Energen has achieved precise and repeatable linear motion from special magnetic smart materials (MSM). The result is linear actuators that are very reliable and uniquely suited to a wide range of precision motion tasks.

The actuators exploit the special properties of materials that change shape in a magnetic field. The result is motion with no moving parts. No moving parts means less can go wrong - a design engineer's dream.

Originally developed for NASA and the US Department of Energy, they have achieved their goals of increased reliability, reduced costs, improved performance and weight savings. Proven in demanding applications in space and in particle accelerators, Energen actuators are now available as standard products and customized solutions for industrial applications.

Energen's expertise in magnetic "smart" materials (MSM) has enabled innovative positioning, vibration control, and shape control solutions. MSM-based solutions span a size scale of six orders of magnitude, from microvalves enabling microfluidic and sensing applications to elevator brakes and jet blast deflectors with tens of thousands of pounds of force capability. Energen actuators and linear motors are being applied successfully to diverse applications such as precision positioning of telescope optics, active vibration and jitter control of weapons platforms, and tuning of particle accelerator cavities.

Energen's current development thrust aims to exploit the commercial potential of magnetic smart materials in thin film form. Thin film MSM actuators have the potential to enable more robust drug delivery systems, disposable chemical and biological sensors, lightweight large-scale optics, and many other applications not yet envisioned.

Energen's success in delivering high value-added solutions to its customers derives from its collaborative business model. The Company partners with academic institutions, national laboratories, government agencies, and industry to pursue application-specific opportunities in its customer's market niche. Through these partnerships, our customers leverage their resources by accessing a broader range of technology than that in which they invest directly.

Since its founding in 1996, Energen has developed a proven track record of successful cross-disciplinary collaboration, having delivered state-of-the-art solutions to commercial customers and the Federal Government, funded in part through 15 SBIR awards. Energen has assembled a team of recognized experts and has a reputation for quality.

Actuator Specifications

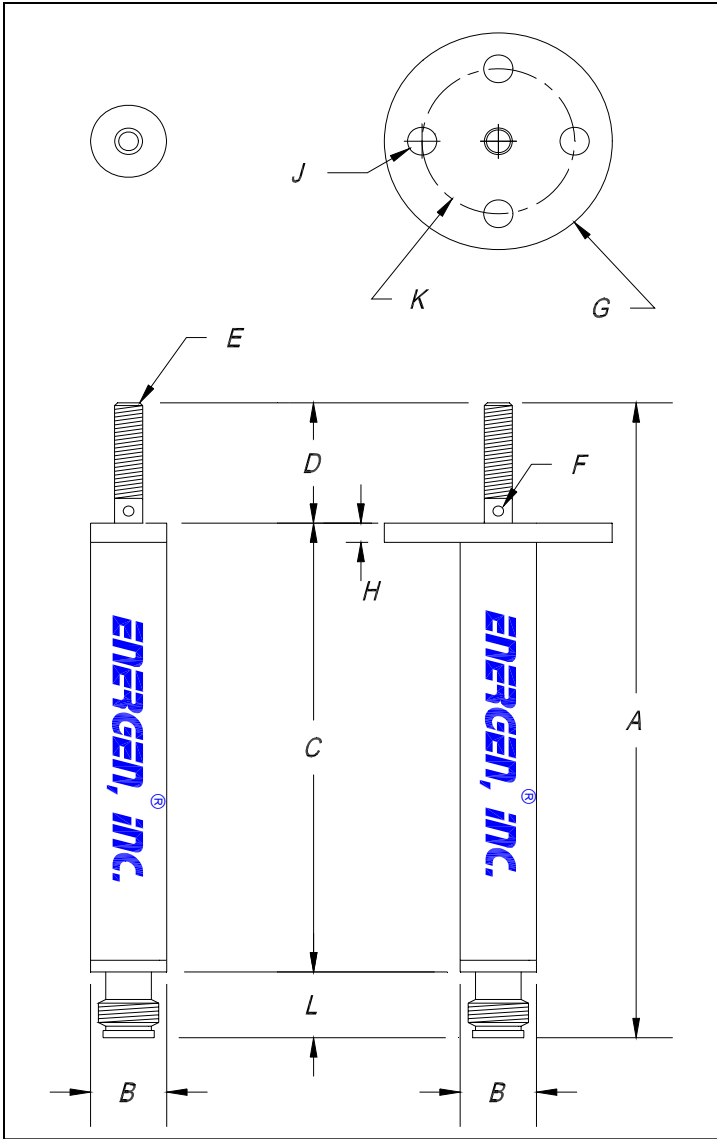

Actuator Series	3	3S ¹	4	4S ¹
Max Stroke ² (μm)				
293K	25		25	
77K	50		110	
4.2K		50		110
Max Force ² (N)				
Push	420	420	650	650
Pull	44	44	140	140
Response time (ms)	0.26	2.0	0.38	13.0
Resolution (μm)	0.05	0.05	0.05	0.05
Max Voltage	1.9 V	Negl.	8.5 V	Negl.
Resistance (Ω)				
293K	1.9		8.5	
77K	0.2		1.2	
4.2K	0.02	0.0	0.01	0.0
Inductance (mH)	0.5	0.5	3.25	3.25
Operation Temperature (K)	10-325	< 9	10-325	< 9

¹ uses a superconducting coil
² stroke is affected by the force and stiffness of the load it is pushing against

Actuator Product Code

n-abc (example: 3-KFM)

n = Size

3 - 3/8" Actuator

4 - 1/2" Actuator

a = Operating temperature

K - KelvinAll

L - superconducting

b = Mount

C - Clamp mount

F - Flange mount

c = Thread sizes

E - English threads

M - Metric threads

Dimension	3-Series		4-Series	
A	3.3"	85 mm	5.0"	128 mm
B	0.37"	9.4 mm	0.50"	12.6 mm
C	2.36"	60 mm	4.06"	103 mm
D	0.62"	16 mm	0.62"	16 mm
E	6-32UNC	M3.5x6.0	10-32UNF	M3.5x6.0
E	0.5"	12 mm	0.5"	12 mm
F	0.052"	1.3 mm	0.063"	1.6 mm
G	1.12"	28 mm	1.50"	38 mm
H	0.13"	3.3 mm	0.13"	3.3 mm
J	0.144"	3.7 mm	0.20"	5.0 mm
K	0.75"	19 mm	1.00"	25.4 mm
L	0.36"	9 mm	0.36"	9 mm

ENERGEN, INC.

650 Suffolk Street, Lowell, MA 01854 USA

Tel: +1 978-259-0100

Fax: +1 253-550-1767

www.EnergenInc.com

sales@EnergenInc.com